

## Lawn de-thatcher

(Guide only)

### BEFORE USE

1. Read and understand the Hazard Assessment Sheet.
2. Mow the lawn 1/2 inch shorter than normal.
3. Allow the lawn to dry. Wet conditions can cause extensive damage to healthy grass.

### FLAIL BLADES OR SPRING TINES

1. Flail blades or spring tines: Set blade or tine depth so that the blades or tines just touch on a flat surface such as a sidewalk or driveway. Blades should never contact soil.
2. Lawns with deep thatch exceeding .78 inches (2cm) may be best dethatched in two treatments (spring and fall) to avoid major shock to an older lawn.

### STARTING

1. Set the transport lever in working position.
2. To engage the clutch in heavy thatch, bear down on the handle and raise the front wheels slightly. Hold the clutch engaged against the handle and carefully lower the machine into the turf.
3. Perform a small test area at a slow walking pace.
4. If the engine speed drops excessively, the depth setting is too deep. Adjust depth lever up.
5. If the machine pulls forward and bucks roughly, the depth setting is too deep. Check for stones or fixed objects in the lawn. Adjust depth lever up.



**Stay alert, don't get hurt**

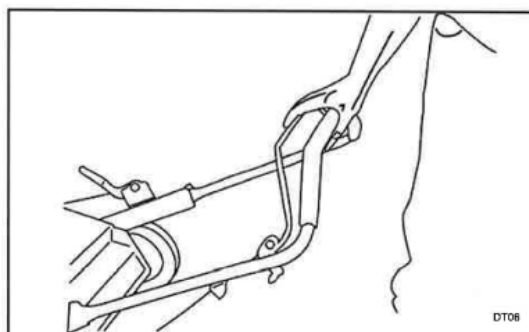
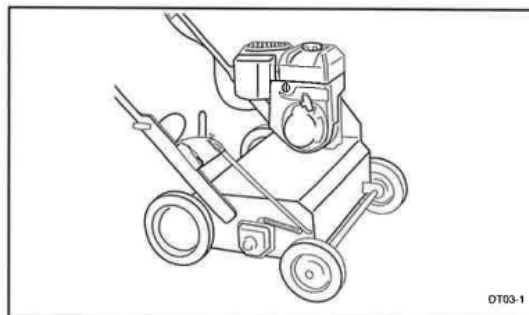

### IMPORTANT INFORMATION

CLEAR THE LAWN OF ANY DEBRIS.  
CLEARLY MARK ROCKS AND OTHER FIXED OBJECTS.  
BE ESPECIALLY SURE TO CHECK FOR HIDDEN ELECTRICAL CABLES OR SIMILAR IN THE SURFACE OF THE LAWN.

## RUNNING

1. Do NOT use the machine on grades more than 20°. It is recommended to work across slopes rather than up and down. This will yield a more even result. Do NOT leave the machine standing on a slope unattended.
2. Do NOT use the machine if you are tired, have consumed alcohol or if you are taking other drugs or medication that can affect your vision, judgement or coordination.
3. Never use the machine indoors or in spaces lacking proper ventilation.
4. Do not use the machine on any surface other than grass.
5. Make sure you have a proper foothold when using the machine, particularly when backing. Walk, don't run. Never work on wet grass. Poor traction may cause you to slip.
6. Keep your hands and feet away from moving parts.
7. Keep your hands and feet away from the work tools.
8. Slow down and be especially careful on slopes. Make sure to run the machine in the recommendation direction on slopes. Be careful when working close to sudden changes in level.
9. Smoking, open flames or sparks in the vicinity of the machine are **strictly** forbidden. Gasoline is extremely flammable and carelessness in handling can result in personal injury or fire.
10. Stop and inspect the equipment if you run over or into anything. If necessary make repairs before beginning again.
11. Whatever happens, you should always park the machine on even ground, disengage the drive, turn off the engine and wait until all moving parts have stopped before leaving the operation position behind the machine.

## WARNING

ENGINE EXHAUST, SOME OF ITS CONSTITUENTS AND CERTAIN VEHICLE COMPONENTS CONTAIN OR EMIT CHEMICALS CONSIDERED TO CAUSE CANCER, BIRTH DEFECTS OR OTHER REPRODUCTIVE HARM. THE ENGINE EMITS CARBON MONOXIDE, WHICH IS A COLOURLESS, POISONOUS GAS. DO NOT USE THE MACHINE IN ENCLOSED SPACES.



The engine exhaust is poisonous. Never run the engine indoors.



Keep your hands and feet away from moving parts.



Smoking near the machine is **strictly** prohibited.

## FINISHING

1. Remove all extended thatch from the grass and compost/dispose of properly.
2. Other methods for improving your lawn may include aeration and fertilization.

# MANDATORY PERSONAL PROTECTIVE EQUIPMENT



## TROUBLESHOOTING

Problem	Possible solution

**Do not under any circumstances attempt any repairs. Please call your local Hiredepot branch for assistance.**

This operating and safety brochure is intended as a guide only for the safe operation of this equipment. It does not override license requirements nor is it a substitute for structured operating lesson. If you are unsure about any aspect of the equipment, its capabilities or the correct usage, please call our trained staff for instruction or any questions you may have regarding the safe operation of this equipment.

When service matters.  
**hiredepot.com.au**

**GLEN IRIS**  
70 High St  
9885 4431

**FAIRFIELD**  
323 Darebin Rd  
9499 9955