

## Twin drum roller (RD11)

SPECIFICATIONS	
Engine type	4-stroke, 2 cylinder, air-cooled
Engine model	GX 610 QDF
Fuel	Regular unleaded gasoline
Outside turning radius	2.8m
Weight	1,200kg
Power	26kW diesel engine
Dimensions	2395m(L) x 1310mm (W) x 2640mm (H)
Travel speed (forward / reverse)	9km/h
Dry weight	925kg
Water tank capacity	150L



### STANDARD FEATURES

- Articulated steering increases manoeuvrability
- Powerful fuel efficient engine
- Pressurised water sprinkler system
- Flush finish on asphalt

### ALSO REFER TO:

- Twin drum roller operating procedure
- Twin drum roller hazard assessment sheet

### RELATED ITEMS

- Vibrating plate
- Wacker rammer

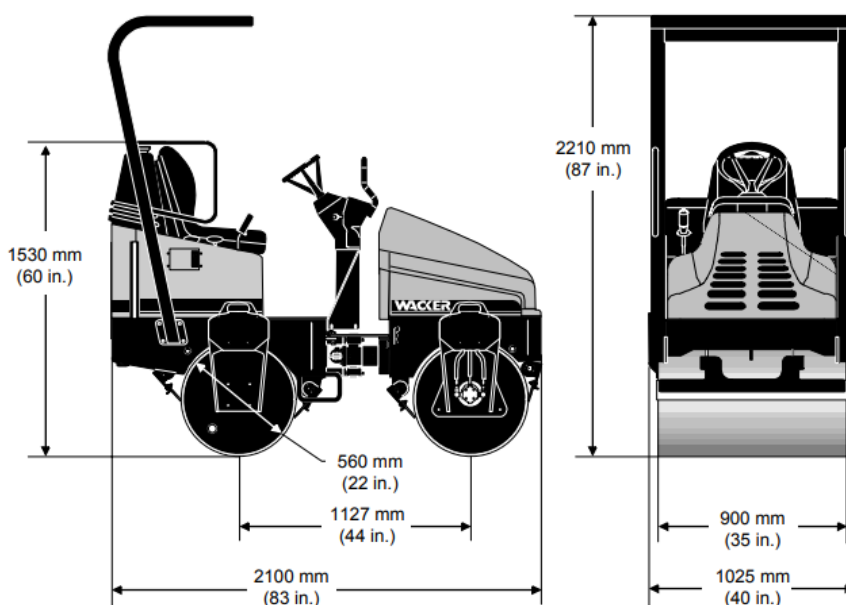

### MANDATORY PERSONAL PROTECTIVE EQUIPMENT



**Do not under any circumstances attempt any repairs. Please call your local Hiredepot branch for assistance.**